



- 3 AC systems and 3/N AC systems



- electronic measuring relay
- indicates voltage asymmetry
- no additional auxiliary voltage required
- impulse voltage and electrical disturbance proof according to VDE and IEC
- alarm relay with two change-over contacts
- built-in power on LED and alarm LED
- continuously adjustable alarm points
- compact 45 mm casing

Function

When the relative difference in line to neutral voltage of one or two of the line conductors exceeds the adjusted response value "Y(%)" the alarm relay K1 releases and the red alarm LED signals "% $\Delta U_{VW} \dot{I} N > Y$ ".

Symmetrical change of all lines to neutral is not indicated as long as the change is within the operating range. Below the operating range the relay K1 releases.

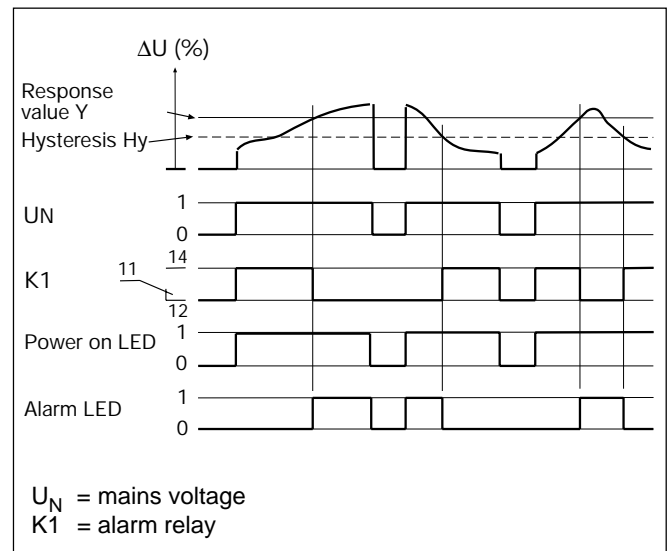

Dimension diagram

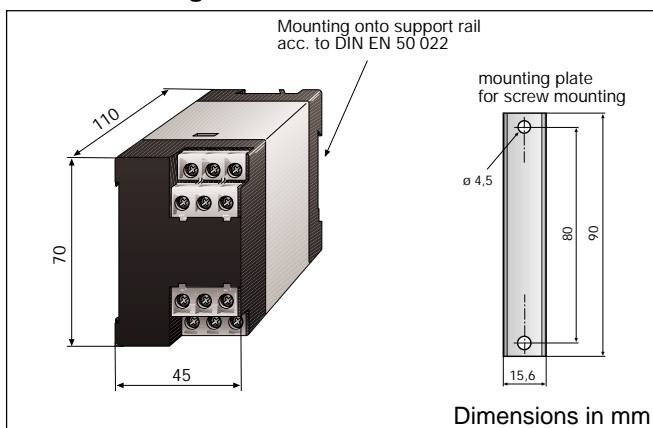

Delay on response and on release

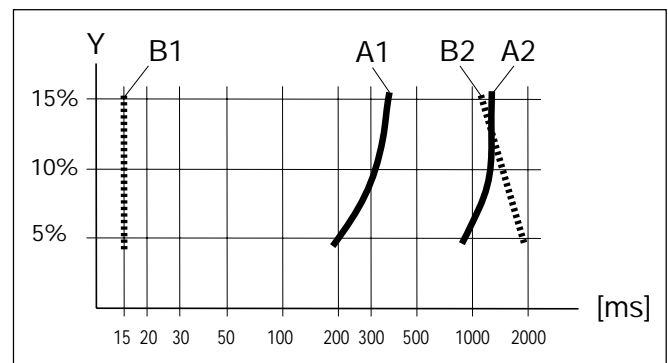

Delay on response

- A1 = Changing from U_N to 0V (1 or 2 lines)
- A2 = Changing from U_N to $1,1 \times Y$ (1 or 2 lines)

Delay on release

- B1 = Changing from 0V to U_N (3 lines)
- B2 = Changing from 0V to U_N (1 line)

Technical Data SAD140

Insulation coordination acc. to IEC 664-1:

Rated insulation voltage	AC 440 V
Rated impulse withstand voltage/contamination level	4 kV/3
Dielectric test acc. to IEC 255	2.5 kV

System being monitoring

Nominal voltage of the system U_N	3/N/AC 50...60 Hz 440 / 254 V, 400 / 230 V oder 230 / 133 V
Operation range of U_N	0.7 ... 1.15 x U_N

Supply voltage

Supplied by the system to be monitored	
Max. power consumption	2.5 VA

Response values

Response value (adjustable)	5 ... 15 %
Repeat accuracy	2 %
Influence of ambient temperature	< 0.05 % / °C
Influence of frequency	< 0.1 % / Hz
Switching hysteresis	ca. 3 %

Contact circuit

Switching components	2 change over contacts
Contact class acc. to DIN IEC 255 Teil 0-20	IIB
Rated contact voltage	AC 250 V/DC 300 V
Admissible number of operations	12000 cycles
Limited making capacity	UC 5 A
Limited breaking capacity	
at AC 230 V and $\cos \phi = 0.4$	AC 2 A
at DC 220 V and $L/R = 0.04$ s	DC 0.2 A
Operating principle	N/C operation

Type tests

Test of the Electromagnetic Compatibility (EMC):

Immunity against electromagnetic

Interferences acc. prEN 50082-2:

Impulse voltage and electrical disturbance test acc. to IEC 255:	
Impulse voltage test acc. to IEC 255-5	class III
Electrical disturbance test acc. to IEC 255-5	class III

Emissions acc. to EN 50081-2:

Emissions acc. to EN 55011/CISPR11	class B ¹⁾
------------------------------------	-----------------------

Mechanical tests:

Shock resistance acc. to IEC 68-2-27	15 g/11 ms
Bumping acc. to IEC 68-2-29	40 g/6 ms
Vibration strength acc. to IEC 68-2-6	10 ... 150 Hz/0.15 mm - 2 g

Environmental conditions

Ambient temperature, during operation	-15°C ... +50°C
Storage temperature range	-20°C ... +70°C
Climatic class acc. to IEC 721	3K5, except condensation and formation of ice

General data

Operation class	continuous operation
Mounting position	any position
Type of connection	terminals with self-lifting clamp-washers
Wire cross section	
single wire	2 x (1...1,5 mm ²)
fine braid	2 x (0.75...1,5 mm ²)
DIN rail	according to DIN EN 50 022 or screw mounting

Protection class acc. to EN 60529

Internal components	IP 50
Terminals/with terminal covers	IP10/IP 20
Type of casing	X140
Flammability class	UL94V-0
Weight	approx. 300 g

¹⁾ Class B devices are suitable for household and industrial use.

Wiring diagram

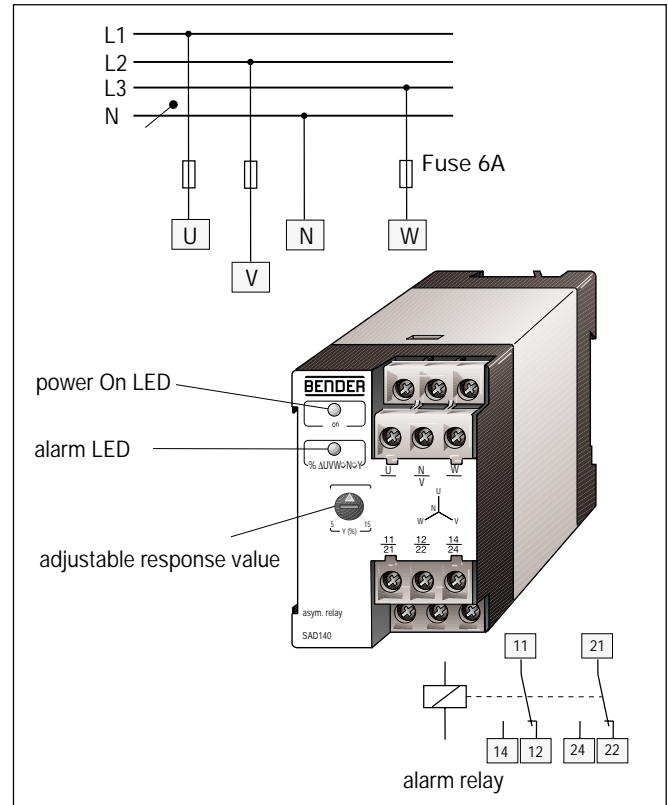

Safety instructions

Please check for correct mains voltage !

Electrical equipment shall only be installed by qualified personnel in consideration of the current safety regulations.

For short-circuit protection, the network coupling has to be equipped with a protective device according to IEC 364-4-473 (A fuse of 6 A is recommended).

Supplementary to this data sheet you will find enclosed "important safety instructions on the proper use of BENDER products."

Ordering details

Type	Rated system voltage U_N	Art.No.
SAD140	3 / N AC 230 / 133 V	935 163
	3 / N AC 400 / 230 V	935 124
	3 / N AC 440 / 254 V	935 510

Other values on request

Ordering details for screw mounting

Type	Art. No.
Mounting plate	300 102

BENDER Industrial Products

700 Fox Chase, Coatesville, PA 19320
Tel. (800) 356-4266 - Fax. (610) 383-7100
www.benderrealay.com