

Product Description

The measuring current transformers (CT) W0-S15 ... W5-S210 are suitable for use with RCM and EDS-based products to detect and locate ground faults in grounded, high-resistance grounded and ungrounded systems.

In combination with RCM, RCMS and EDS-based products, the current transformers have a sensitivity extending over the range of 1mA...20A. Load current is not a factor when selecting the proper current transformer. The current transformer should be selected based on the cable size.

The measuring current transformers W0-S15 ... W5-S210 are designed with different openings to accommodate a wide range of cable sizes. The W0-S15..W5-S210 are made from a high density Mu metal which has unique and repeatable output characteristics. Connection is by screw terminals. Depending on the application, the current transformers can be mounted either directly on the cable or by using the mounting brackets.

Dimension Diagram (mm)

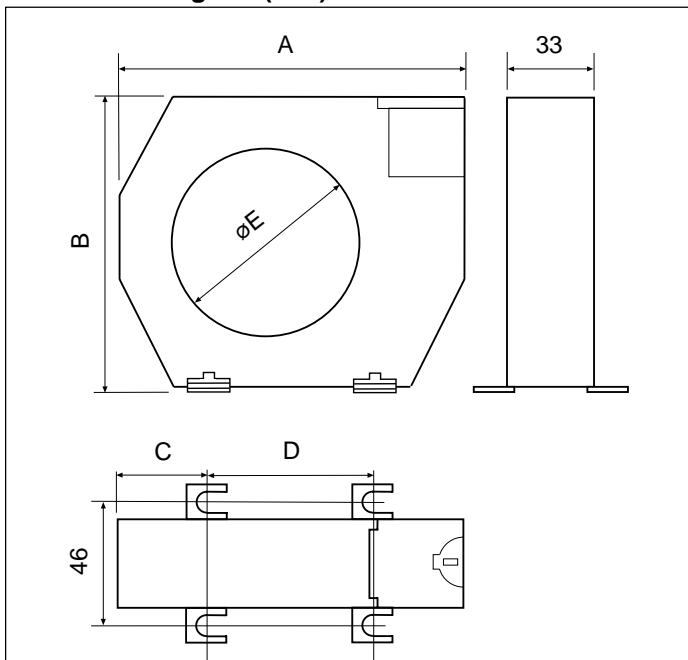

Dimensions (mm)

Type	A	B	C	D	øE	kg
W0-S15	see	below			14.5	0.25
W1-S35	100	79	26	48,5	35	0.25
W2-S70	130	110	32	66	70	0.38
W3-S105	170	146	38	94	105	0.70
W4-S140	220	196	48,5	123	140	1.50
W5-S210	300	280	69	161	210	2.50

Operational Information

The measuring current transformers W0-S15 ... W5-S210 are highly sensitive and accurate current transformers which convert ground fault leakage currents into a signal that can be processed by either a RCM or EDS based product. Connection to the appropriate device is by two wires to the [K] and [L] terminals. Depending on the selected type of cable, up to 25 m (80 ft) distance between the current transformer and ground fault evaluator is allowed. It is essential that all circuit conductors of the appropriate electrical system to be monitored be guided through the current transformer. This would be for example, L1 and N for single phase, L1, L2, L3 and N (if connected) for three-phase systems.

The equipment grounding conductor must always bypass the current transformer when wiring the system conductors through the CT.

In certain special cases, you may pass just the ground wire through the CT and the system conductors would bypass the current transformer when using the CTs in an RCM application. This should only be considered if the system conductors are too large for the CT.

Cable routing through the measuring transformer

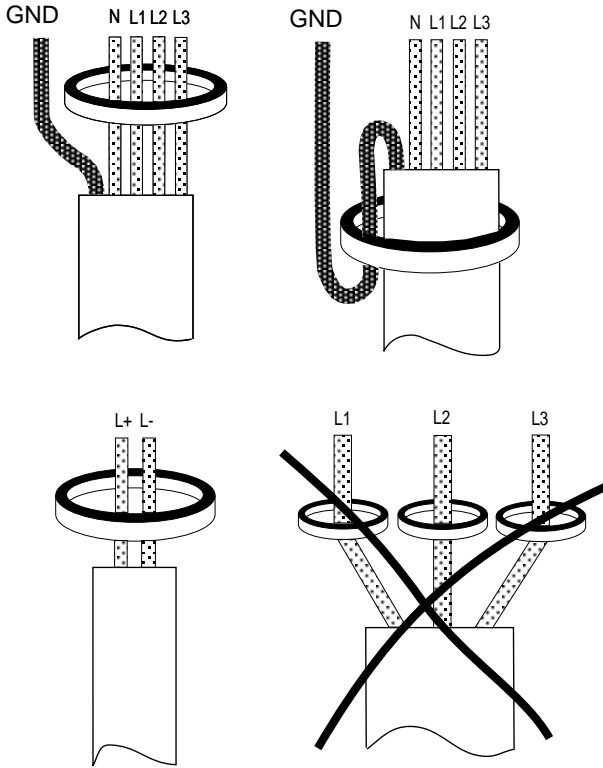

Avoiding interferences in case of high inrush currents

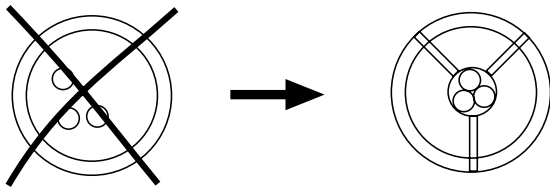

Dimension Diagram - W0-S15
(all dimensions are in mm)

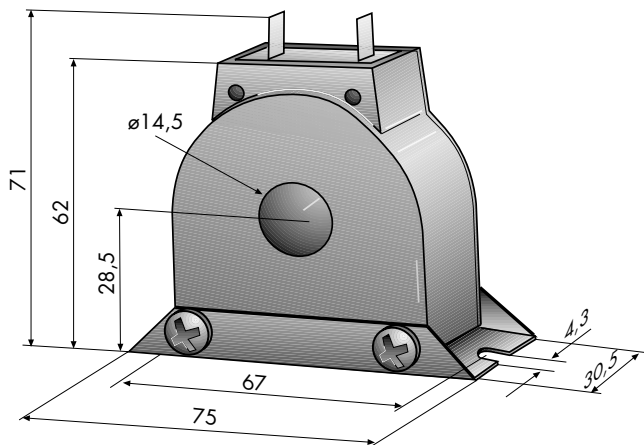

Technical Data W0-S15 ... W5-S210

General Data:

Rated burden	180Ω
Rated ground fault sensing current	10A
Continuous ground fault overload capacity	20A
Rated short-time thermal current (1 sec.)	14 kA
Nominal power	500 mVA
Frequency Range	15Hz...400Hz
Accuracy	99%
Ambient temperature	-10°C ... +50°C
Flammability class	UL94V-0
Rated transformation ratio	600:1
CT material	high density Mu metal

Testing:

Rated insulation voltage acc. DIN VDE 0110 T.1	AC 630 V
Rated impulse withstand voltage/ contamination level	6 kV/3
BIL Rating	2 kV
Dielectric test voltage acc. DIN VDE 0435 T.303/IEC 255	AC 3 kV

Connections & Mounting:

Length of the connecting leads	
Type of connection to the measuring transformer	
Single wires	up to 3' (1 m)
Twisted pair cable	up to 30' (10 m)
Shielded twisted pair cable	up to 75' (25 m)
Screw mounting	#10

Ordering Guide

Model	Internal Diameter mm (inches)	Article Number
W0-S15	15mm (9/16")	911753
W1-S35	35mm (1-3/8")	911731
W2-S70	70mm (2-3/4")	911732
W3-S105	105mm (4-1/8")	911733
W4-S140	140mm (5-1/2")	911734
W5-S210	210mm (8-1/4")	911735

Split-core & rectangular current transformers also available